

WIRINGS CONNECTION DIAGRAM

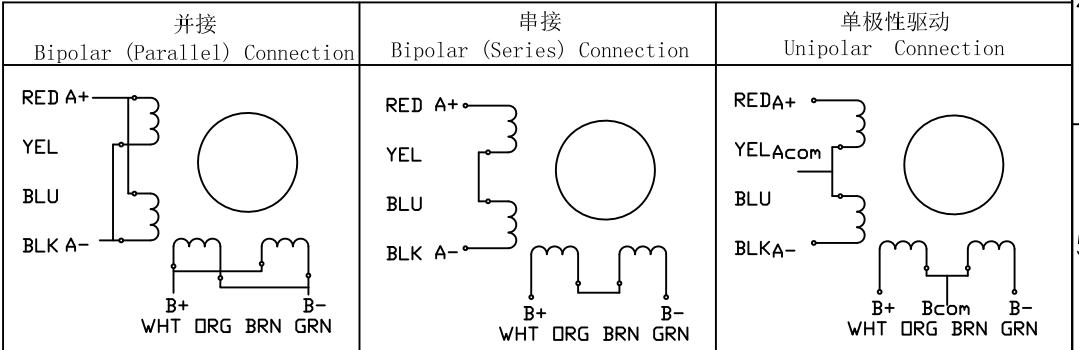

	最大静转矩 Holding Torque (2 phases on) N. cm ±10%	额定电流/相 Rated Current/Phase (Amps DC)	相电阻 Resistance/Phase (ohms) ±10%	电压/相 Voltage/Phase (V DC)	电感/相 Inductance/Phase (mH) ±20% Typical (kHz)
单极性驱动 Unipolar	410	4.2	0.8	3.36	3.4
串接 Bipolar (Series)	579	2.97	1.6	4.75	13.26
并接 Bipolar (Parallel)	579	5.94	0.4	2.37	3.4

Unit: mm 第一角画法 First angle method 未注线性与角度尺寸公差 Tolerances for linear and angular dimensions without individual tolerance indications GB/T 1804-m eqv ISO 2768-1:m 未注形状与位置尺寸公差 Geometrical tolerances for features without individual tolerance indications GB/T 1184-k eqv ISO 2768-2:k	DATE
--	------

设计 DESIGN		
校核 CHECK		
工艺 TECHNOLOGY		
标准化 STANDARD		
批准 APPROVE		
NAMES	SINGATURE	DATE

METALTEX

Model: **MP86-P080**

TYPE: HYBRID STEPPING MOTOR SCALE XX Rev. 1.0 SHEET 1 OF 1